

# SERVICE MANUAL SUPERIOR SUE-05

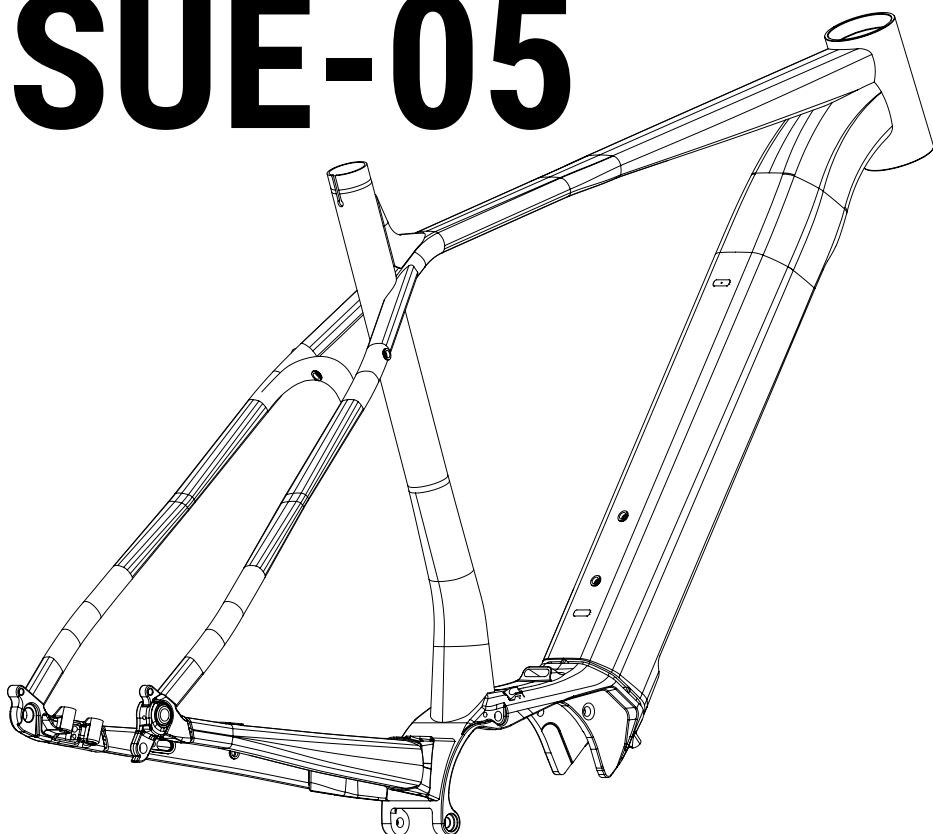

# SUPERIOR SERVICE MANUAL

Superior would like to congratulate you on the purchase of your new bicycle. We place great emphasis on the choice of materials and their processing so as to ensure the highest quality of our products, a long service life and great functionality.

The Servis Manual contains and specifies certain rules that should be followed if you want to enjoy your high-quality Superior product for many years to come. You have received the Operating Manual with your bike.

Superior supplies high-quality bicycles exclusively for specialized shops. These products are already partially pre-assembled.

The final assembly of a bike for riding can only be carried out by an authorized Superior dealer. This particularly applies to the basic configuration of suspension components, the front and back derailleurs and braking systems. This will ensure maximum safety when using the product.



## WARNING

### WARNINGS RELATED TO MECHANICAL WORK

*Specialized skills and tools are required to configure and tune the bike. These tasks should only be carried out by employees at an authorized service station. Riding a bike that has not been correctly configured and assembled can be dangerous. Even a seemingly minor deficiency, such as a loose screw, can cause a crucial part to break over time and the loss of control of the bike, leading to an accident. Therefore, we recommend that you leave any repairs and maintenance for your bicycle to an authorized service centre. Your safety depends on the correct maintenance of the bike. Employees of authorized service stations have special qualifications and know-how.*



## WARNING

*Any adjustments and modifications can lead to the frame, fork or other parts becoming unsafe. The use of an unapproved component or the incorrect assembly of parts can lead to excessive wear and tear of the bike or its parts. Adjustments to the frame, fork or other components can have a negative impact on the handling of the bike and may lead to a fall. Do not grind off, drill or file any parts, do not remove backup safety elements, do not install incompatible forks and do not make any other similar unauthorized changes. Before you install any accessories on your bicycle, or replace any part, always consult the authorized service center to make sure the particular accessory or part is compatible and safe to use.*

# BIKE CATEGORY

This bikes are equipped with only front suspension fork with short travel and are constructed for "standard" rides, assuming adherence to type-2 operating conditions:

### Type-2 operating conditions

Riding on paved roads and unpaved and gravel roads and trails with moderate grades. In this set of conditions, contact with irregular terrain and loss of tire contact with the ground may occur. Drops are intended to be limited to 15 cm (6 in.) or less.

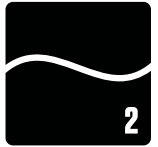

# PREVENTING DAMAGE

- Avoid contact with hard or sharp items. Do not rest your bike with the top tube of the frame against a column or corner of a building.
- When fixing the wheel, place the entire bike in a stand and clamp the seatpost and avoid high side loads; this especially applies when replacing the bottom bracket and cranks/crankset. High loads can lead to damage of the seatpost or frame.
- When transporting the bike on a car, use a bike carrier that fixes the bike using the seatpost or front wheel axle. Do not fix the bike to the frame.
- Frames are not suitable for use on stationary bicycles fixed to the rear stay. The bike then cannot move, which leads to excessive load on the end of the frame. This can cause damage to the frame.
- The frame is not suitable for the fixture of any children's seats or carriers.
- If you are transporting the bike in a box, make sure that the bike is kept safe, for instance by using a soft foam cover. Make sure that there are no foreign items or that excessive pressure or force from these items cannot break or damage the frame. Please keep in mind that the warranty does not apply to damage caused during transit.
- Neither the frame nor the carbon components can ever come in contact with high temperatures such as those used in the case of powder spraying or cauterizing varnish. Such temperatures can damage the frame and components. Also avoid leaving the bike in a car in case of strong solar radiation. Similarly, do not keep your bike in the vicinity of sources of high temperatures.

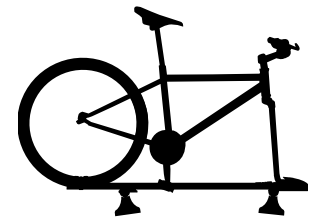

# SERVICE INTERVALS

- Large-scale service – at an authorized service centre, at least 1x per year or after 200 hours of riding.
- Check the tightening of moving parts before and after each ride. The prescribed torques of individual joints (see the diagram below) must be strictly observed.
- Bearings and pivots should be lubricated at least 1x per half a year.
- Consult your dealer about the exact service plan and maintenance schedule of your bicycle. The dealer shall propose the schedule depending on the model of your bicycle and the way you use it. The service intervals stated above are the recommended maximum intervals for regular bicycle maintenance, i.e. they cannot be extended under any circumstance. If you ride your bicycle more intensively, or if your dealer advises you to, we recommend that you shorten the intervals and extend the scope of tasks carried out. For example, if you ride your bicycle in adverse climatic conditions, over hard terrain or if you have equipped your bicycle with specific components with a different service interval and scope of regular maintenance stated by their manufacturer (exact instructions regarding the service of particular components will be provided by your dealer).



## WARNING

The warranty may be voided if the service intervals and prescribed torques are not adhered to.

Tighten the screws of the motor plastic cover only to **0.6 Nm!**

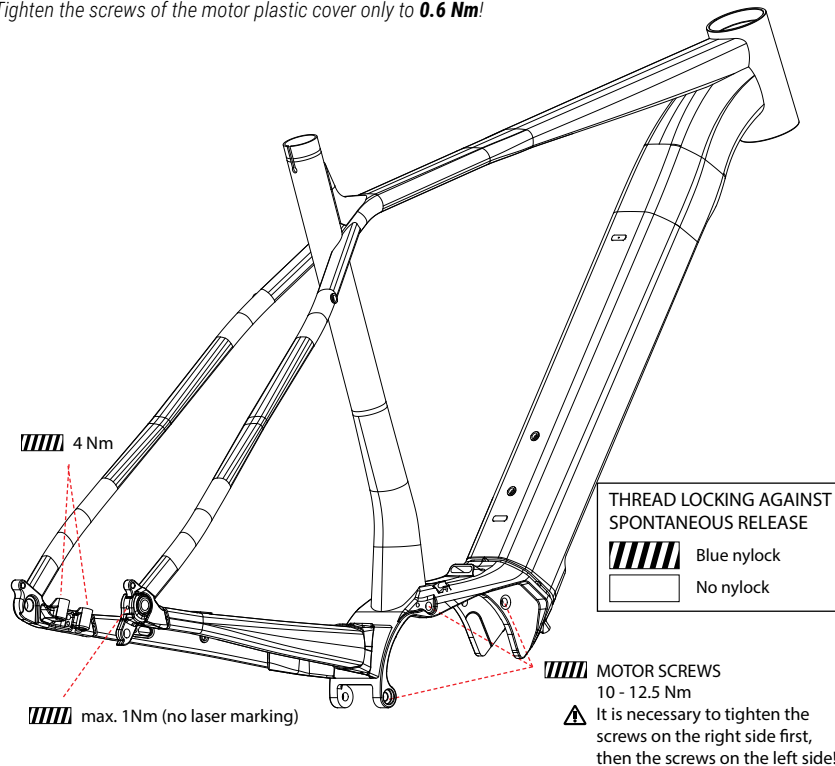

# SETTING THE FORK

## CONFIGURING THE FORK STIFFNESS (SAG)

- The fork must always be unlocked while being configured.
- Move the rubber indication ring located on the inner fork leg to the dust cap.
- Sit on the bicycle with your full weight and then get off it carefully, without rocking the bike.
- Check the position of the ring and make sure that the fork is set in accordance with the values stated in the chart (see below), or adjust the pressure in the fork as needed.

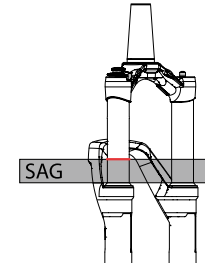

**Depending on your riding style and the way you use your bike, the sag should range between 15-25% of the travel**

Fork		
SAG	%	mm
Travel 65 mm	15 - 20 %	9 - 13 mm

## SETTING THE REBOUND FOR THE FORK

- Rebound is a term used to describe the speed of the fork returning to its original position after absorbing a shock. The control for adjusting the rebound is usually located at the lower end of the fork leg.
- When sitting on the saddle, ride off an edge of approx. 10 -15 cm in height.
- If the fork rocks 1 or 2 times, the rebound is set correctly.
- If the fork rocks more than 3 times, the rebound is too fast.
- If the fork does not rock at all, the rebound is too slow.

# SERVICE

## REPLACING THE CABLES AND HOSES

Ducts are made using guiding tunnels inside of the bicycle frame. The ducts allow easy and quick replacement of cables and hoses within their full length without need to break them.

### 1 REPLACING THE REAR DERAILLEUR CABLE

- 1.1 Slide the old cable out from the guide in the frame.
- 1.2 Slide a new cable in the frame through the hole **A1** and pull it out through the head tube upwards.
- 1.3 Slide the cable through the hole **A2** in the right chain stay.
- 1.4 Fix the cable to the hitch **A3** using a tying strip.

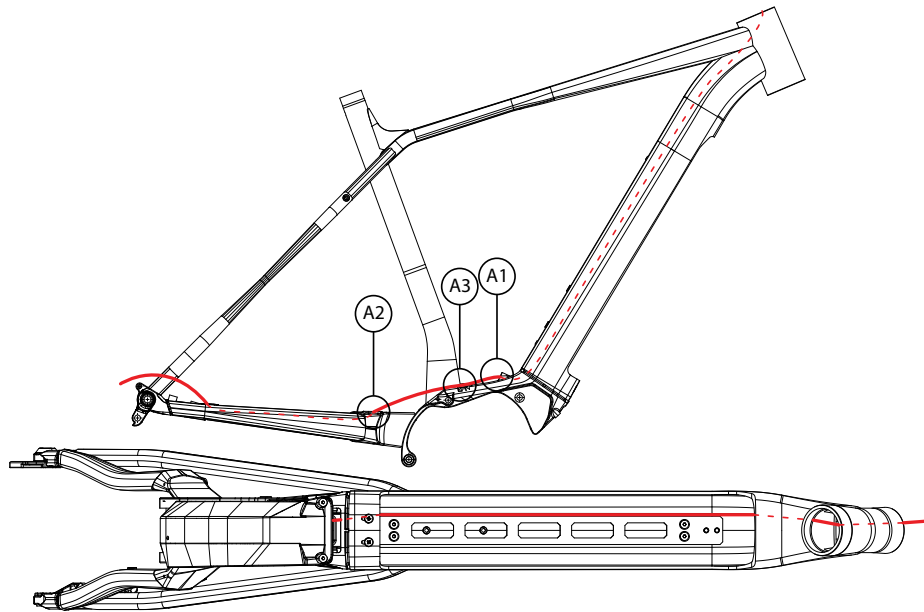

### 2 REPLACING THE HYDRAULIC HOSE OF THE REAR BRAKE

- 2.1 Slide the old hose out from the guide in the frame.
- 2.2 Slide a new hose in the left chain stay through hole **B1**.
- 2.3 Put the hose from the inner side under the main pivot.
- 2.4 Insert the hose through the hole **B2** in the frame and slide the head tube out upwards.

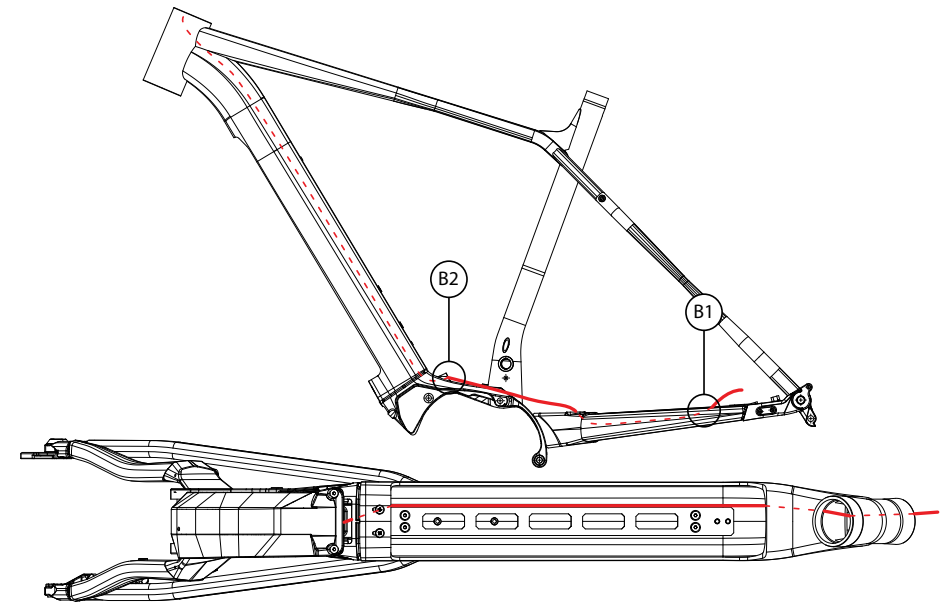

# SERVICE

## 3 REPLACING THE TELESCOPIC SEATPOST CABLE

- 3.1 Slide the old cable out from the guide in the frame.
- 3.2 Slide a new cable in the frame through the hole **C1** and pull it out through the head tube upwards.
- 3.3 Slide the cable in through the hole **C2** and pull it through the seatpost tube.

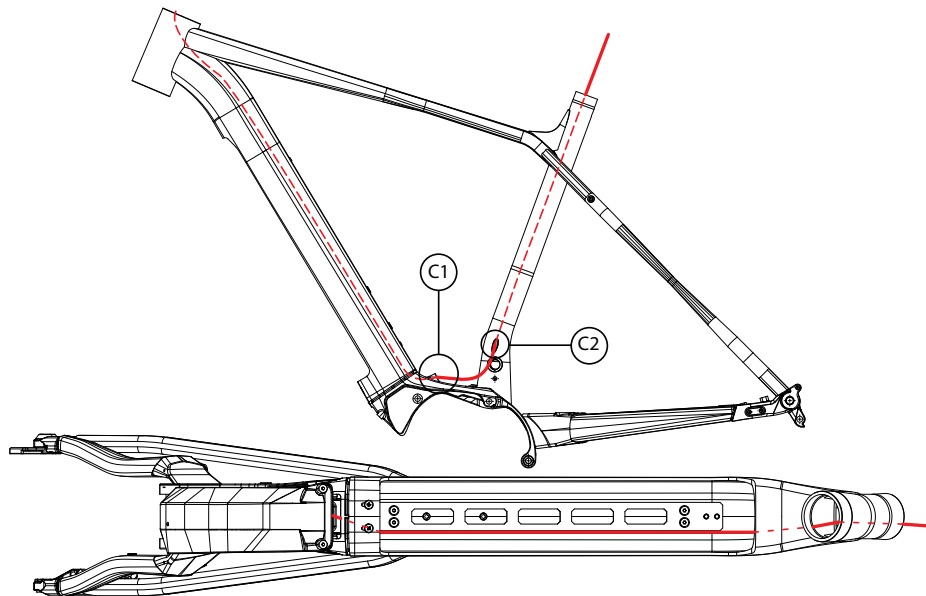

## 4 FASTENING THE CABLES, HYDRAULIC HOSE AND DISPLAY CABLE

- 4.1 Fasten the cables, hydraulic hose and display cable to the docking station bar using tying strips.
- 4.2 Tighten the telescopic seatpost cable so that it would remain movable.
- 4.3 Put the foam **Jagwire SFA07A5M** sleeve on the cables, hydraulic hose and display cable in length only up to the headset.

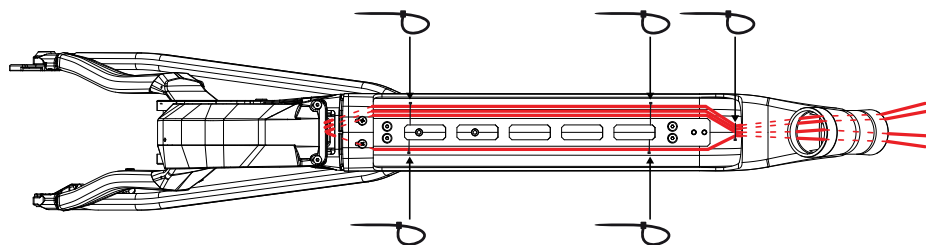

## 5 PULLING THE CABLES, HYDRAULIC HOSE AND DISPLAY CABLE THROUGH THE HEADSET AND SPACER RINGS

- 5.1 Pull the cables, hydraulic hose and display cable through the headset bearing lid and spacer rings so that the telescopic seatpost cable and display cable would be positioned on the right-hand side when viewing from the front **(1)**.
- 5.2 Pull the shifting cable and rear brake hydraulic hose through so that they would be positioned on the left-hand side when viewing from the front **(2)**.

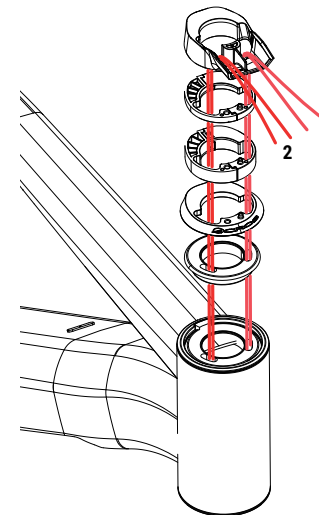

COMPATIBILITY			
Brake Rotors	Front	Ø 160 -180 mm	
	Rear	Ø 140 -180 mm	
Tyre	max. 29 x 2.60"		
Chainring	1x	max. number of teeth 38	
Crankset	Q factor min. 168 mm		
Headset	ACROS AZX-581, ZERO STACK, 1-1/8"x1.5", BLOCKLOCK		
Bottom Bracket	Shimano STePS Middle Drive Unit		
Seatpost Clamp	Ø 34.9 mm	min. clamp height 10 mm	
Seatpost	Ø 30.9 mm	min. insertion / frame size	100 mm / 15.5"-21.0"
		max. insertion / frame size	140 mm / 15.5"
			175 mm / 17.5"
			225 mm / 19.0"
Fork	Travel 65 mm		

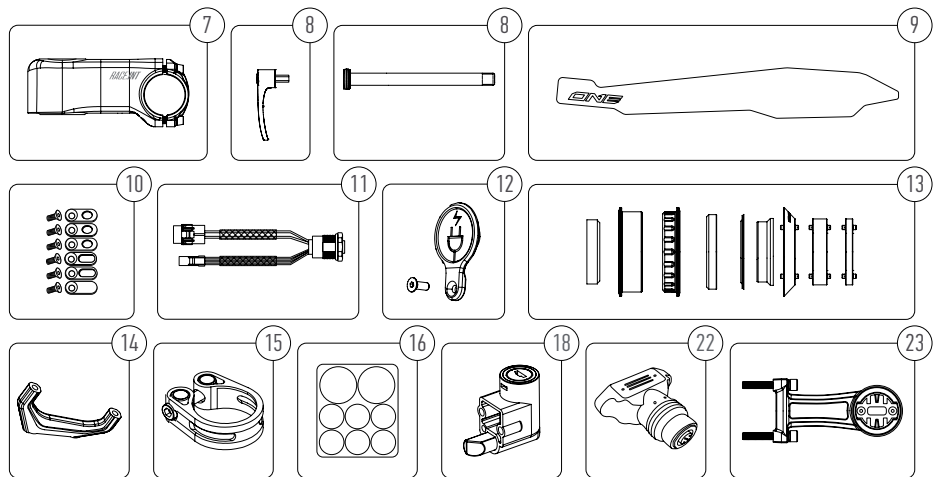
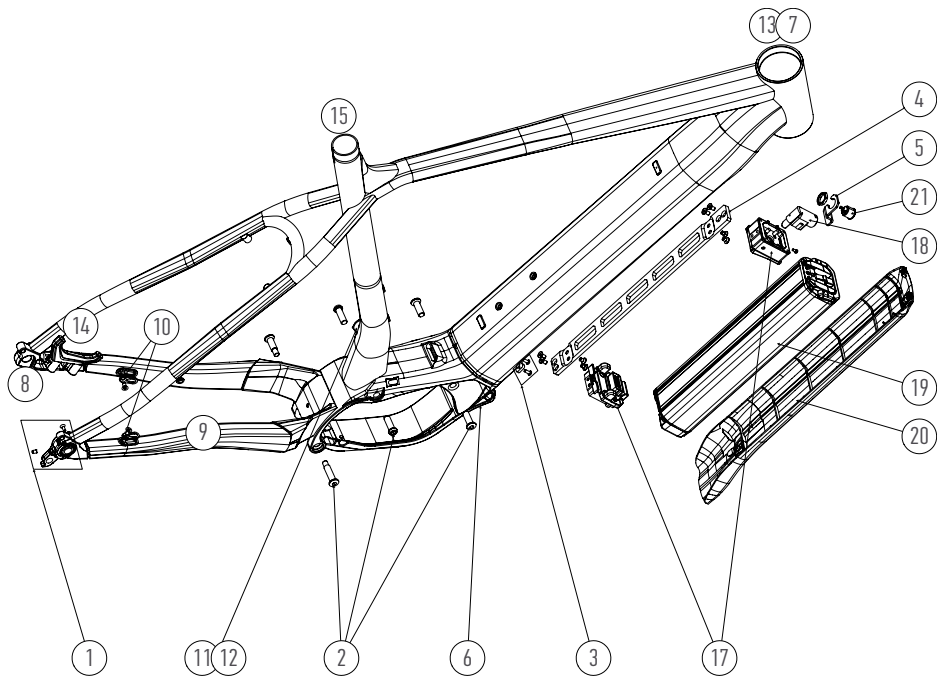

**ORIGINAL ACCESSORIES**

ART. NO.	ITEM	BFI PRODUCT CODE
1	DERAILLEUR HANGER	598.1303.00010
7	MOTOR SCREW SET	598.1303.00022
3	COVER LOCKHOLD	013.0017.00016-372
4	DOCK PLATE	095.0010.00018-372
5	POWER SWITCH HANGER	095.0010.00019-372
6	SKID PLATE	013.0019.00001-372
7	STEM 60 MM	036.2553.00036-196
	STEM 80 MM	036.2433.00021-196
8	E-THRU AXLE	598.1303.00019
9	FRAME PROTECTOR CH/S	087.8000.00022-196
10	INTERNAL CABLE ROUTING SET	013.0003.00129-372
11	CHARGER	095.0008.00019-396
12	CHARGER COVER	095.0010.00023-372
13	HEADSET	009.1205.00002-389
14	DB MOUNT 160 MM	073.0013.00033-372
	DB MOUNT 180MM	073.0013.00034-372
15	SEATPOST CLAMP	011.0302.00096-196
16	FRAME PROTECTOR	087.7000.00009-196
17	BATTERY MOUNT	095.0013.00022-396
18	BATTERY MOUNT LOCK	098.0002.00093-276
19	BATTERY 503 WH	095.0003.00073-396
20	BATTERY COVER	013.0020.00003-196
21	POWER BUTTON	095.0016.00003-396
22	CHARGING ADAPTER	095.0012.00007-396
23	GARMIN MOUNT	036.9000.00013-196

**SMART TIPS**

To improve handling and comfort and to prevent defects, we recommend installing a tubeless system.

# #BEFASTER

Superior is a registered trade mark of  
BIKE FUN International

---

Areál Tatry 1445/2  
742 21 Kopřivnice

---

[www.superiorbikes.eu](http://www.superiorbikes.eu)